

IMHC 2120

OUTREACH (RADIUS): 11 - 51 m
MAX CAPACITY: 120 - 125 t



IMHC 2120

A true allrounder, the IMHC 2120 is the flagship within our range. Flexibility and fast handling of all sorts of cargoes on vessels up to post-panamax size: for bulk with mechanical or 4-rope grabs, coils and containers (telescopic 20' e 40' spreader).

The crane is built in two variants:

1. Single winch with 2 ropes
2. Double winch with 4 ropes (4-ropes grab crane)

GENERAL DIMENSIONS AND WEIGHTS

A	Minimum outreach/Radius	11 m
B	Maximum outreach/Radius	51 m
C	Overall height tower	33 m
D	Tower cab height (operator eye level)	21/24 m
E	Height of boom fulcrum	17,5 m

HOISTING HEIGHTS

F	Above quay level	> 40 m
G	Above quay level at maximum radius	25 m
H	Under quay level	15 m

CHASSIS AND PROPPING SYSTEM WITH STANDARD PADS

I	Overall width of undercarriage	5 m
L	Minimum overall width outriggers	9,8 m
M	Maximum Propping base	12 x 13,4 m
	Chassis dimensions in travel mode (approx.)	16,2 x 9,8 m

TRAVEL GEAR

Axles	6
Steering axles	6
Driven axles	2

OUTREACH/ RADIUS	HEAVY USE	TWIN LIFT	SINGLE LIFT	GRAB USE
m	t Under hook	t Under hook	t Under hook	t Under ropes
11.0	120.0 - 125.0	65.0	50.0	50.0
12.0	120.0 - 125.0	65.0	50.0	50.0
14.0	120.0 - 125.0	65.0	50.0	50.0
16.0	120.0 - 125.0	65.0	50.0	50.0
18.0	120.0 - 125.0	65.0	50.0	50.0
20.0	120.0	65.0	50.0	50.0
22.0	112.5	65.0	50.0	50.0
24.0	102.5	65.0	50.0	50.0
26.0	93.0	65.0	50.0	50.0
28.0	84.5	65.0	50.0	50.0
30.0	80.0	65.0	50.0	50.0
32.0	71.5	65.0	50.0	50.0
34.0	66.5	62.5	50.0	50.0
36.0	61.5	58.5	50.0	48.0
38.0	57.5	55.0	50.0	45.0
40.0	54.0	52.0	50.0	42.0
42.0	50.5	49.0	49.0	39.0
44.0	47.5	46.5	46.5	36.5
46.0	44.5	44.0	44.0	34.0
48.0	41.5	41.5	41.5	32.0
50.0	39.0	39.0	39.0	30.0
51.0	37.5	37.5	37.5	29.0

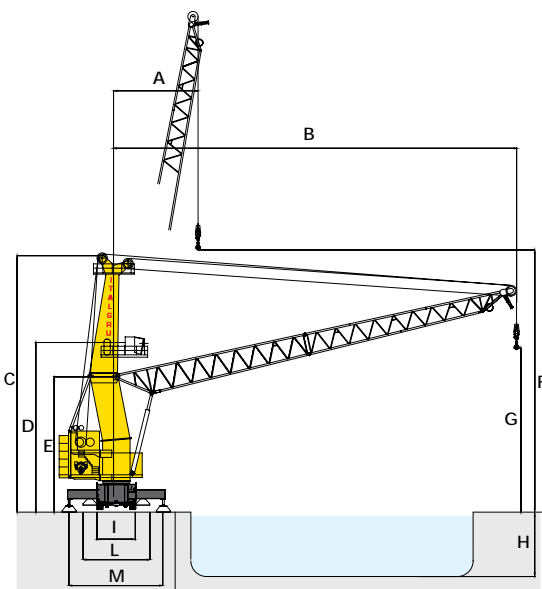

Other dimensions, lifting capacities, working speeds and equipments are available on request.

CONTACT

Ph. +49 2161 639 89 17
 Fax +49 2161 917 49 22
 info@steinberg.gmbh
 www.steinberg.gmbh